

A large, white, stylized Roman numeral 'II' is centered in the upper half of the page. The background is a vibrant teal color with abstract, futuristic patterns. A prominent feature is a large, circular, multi-layered structure resembling a particle accelerator or a light source, with concentric rings and small circular elements. Diagonal lines and a grid of small dots are also visible in the lower half of the image.

Current Status of
Light Sources and
Beamlines

Light Source in 2016

1. Status of UVSOR Accelerators

In the fiscal year 2016, we had scheduled to operate UVSOR-III from May to March, for 38 weeks for users as usual. However, due to a vacuum leakage trouble at the frontend of a beamline and the following recovery works, we canceled the user runs for four weeks and a half in November and December. We had a scheduled shutdown period in April and May for about 6 weeks. This was for the scheduled maintenance works and for replacing the RF power amplifier of the storage ring and the power supply for the injection septum of the booster-synchrotron.

We operated the machine for 31 weeks and a half in the multi-bunch top-up mode, in which the beam current was kept at 300 mA, and 1 week in the single-bunch mode, in which the machine was operated in single-bunch top-up mode with the beam current of approximately 40 mA. The monthly statistics of the operation time and the integrated beam current are shown in Fig. 1. The deep dip around December was due to the vacuum trouble and the recovery work.

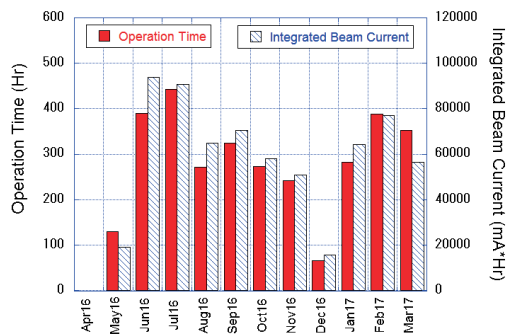

Fig. 1. Monthly statistics in FY2016.

The weekly operation schedule is as follows. On Monday, from 9 am to 9 pm, the machine is operated for machine studies. On Tuesday and Wednesday, from 9 am to 9 pm, the machine is operated for users. From Thursday 9 am to Friday 9 pm, the machine is operated for 36 hours continuously for users. Therefore, the beam time for users in a week is 60 hours. We had 3 weeks dedicated for machine studies, in November, just after the New Year vacation and the last week in March. The machine study week in November is mainly dedicated for the accelerator conditioning after the annual planned power outage.

As described above, the most serious trouble in this year was the vacuum leakage that happened on 23rd Nov. Just after the scheduled beam dump at 9 pm, the vacuum of the storage ring steeply rose. From the record of the vacuum pressure around the ring, it was

suspected that a leakage took place around the frontend of a beam-line, BL3U. This was confirmed by opening the vacuum system on 25th Nov. We found that the cooling water of a mask in the frontend of the beam-line was leaking out to the ultrahigh vacuum. We separated the beam-line from the storage ring by a gate valve and started the recovery work, which involved the baking of the entire ring. After the preparation works, we started the baking of a half of the ring on 5th Dec. and another half on 12th Dec., both of which we continued for one week. We started the machine operation for the vacuum conditioning by synchrotron radiation on 19th Dec. We restarted the user operation on 17th Jan. The beam lifetime recovery during the vacuum conditioning run is shown in Fig. 2.

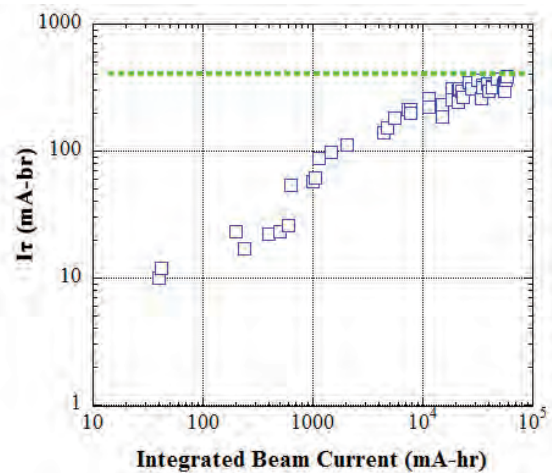

Fig. 2. The lifetime recovery during the vacuum conditioning runs in Dec. 2016 and Jan. 2017. The horizontal axis is the integrated beam current and the vertical axis is the life time multiplied by the beam current ($I\tau$). The lifetime just before the vacuum accident is shown by a blue dotted line.

In this year, other than the vacuum trouble described above, we had a few minor troubles on the power supplies of the injection/extraction magnets. However, fortunately, in all cases the beam time for users was not lost. The water leakages from a quadrupole magnet in the booster synchrotron happened but it was recovered by replacing the water cooling pipe during the shutdown period.

2. Improvements and Developments

The solid state 90 MHz RF power amplifiers of the booster synchrotron and of the storage ring had been used for about 20 years. They had been working well without any serious problem. However it became difficult to maintain them because of the outage of

electronic parts. We decided to replace the amplifiers with new ones which have basically same performances but much smaller sizes and are water cooled. We expect that the water cooling would be beneficial to stabilize the accelerator room temperature and also to reduce the sound noise in the experimental hall. In the spring shut down 2015, we replaced the amplifier for the booster synchrotron. It had been working well without any serious problem for one year. Then, in this year, we have replaced that of the storage ring. The new RF amplifier had an electric noise problem, however, it was soon improved by adding some filters.

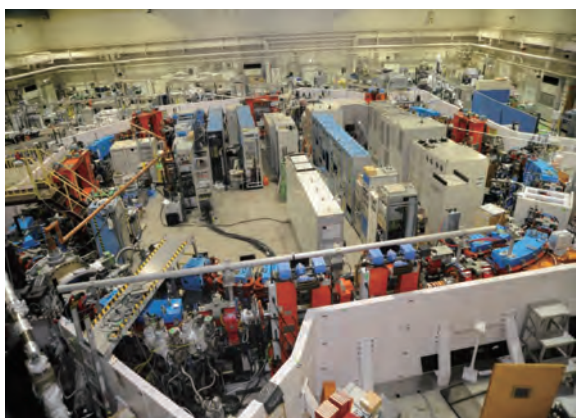

Fig. 3. An open space appeared in the storage ring after removing the old RF power amplifier.

Light Source Developments and Beam Physics Studies

We continue the efforts to develop light sources technologies and their applications such as free electron lasers, coherent harmonic generation, coherent synchrotron radiation, laser Compton scattering gamma-rays, intense polarized and vortex UV radiation at the new source development station BL1U, which was constructed under the support of Quantum Beam Technology Program by MEXT/JST. This beam-line is dedicated to develop light source technologies and to explore their applications.

This year, we continued studying the optical vortex beam from a helical undulator in collaboration with Hiroshima U., Nagoya U. and other institutes. Since the UVSOR electron beam is diffraction-limited in the

UV range, we could precisely investigate the optical properties of the vortex beams from undulators in this wavelength range using conventional optical components such as a UV-CCD camera, bandpass filters and so on. In the spring shut down 2016, we collaborated with the beamline staffs, and installed a mirror and a monochromator at BL1U, which would be used for exploring the applications of novel light sources. By using this beam-line, we continued the experimental study on the interaction between optical vortex VUV light and atoms in collaboration with Saga LS and Niigata U. [1]. As a theoretical work, we have successfully shown that the origin of the vortex nature of the undulator radiation was in the radiation from an electron in circular motion [2].

We are continuing the effort to reconstruct the optical cavity for the resonator free electron laser at BL1U, which has been investigated for many years at UVSOR. This time, the main objective is the high flux intra-cavity gamma-ray production for the nuclear resonance fluorescence imaging in cooperation with Kyoto University. Currently gamma-rays are produced by using conventional fiber laser for the proof-of-principle study [3]. The gamma-rays are also used for investigating the origin of the homo-chirality of biomolecules in nature in collaboration with Hiroshima U., Yokohama N. U. and others.

Irradiation experiments using polarized ultraviolet light are being carried out in corporation with Tokyo U. Sci. and with Yokohama N. U and Hiroshima U. In the latter case, the circularly polarized UV-VUV light was used for the study on the origin of homo-chirality [4]

A spin polarized electron gun is being developed in collaboration with Nagoya U. and KEK. This year, the temporal response of the photocathode was investigated by using femto-second laser system at BL1U [5].

We continued designing a new harmonic cavity in collaboration with Nagoya U., to replace the present cavity which has a vacuum trouble. For this design study, we have started investigating present beam instabilities at UVSOR-III [6].

[1] T. Kaneyasu *et al.*, in these reports

[2] M. Katoh *et al.*, in these reports

[3] H. Zen *et al.*, in these reports

[4] K. Matsuo *et al.*, in these reports

[5] N. Yamamoto *et al.*, in these reports

[6] A. Mochihashi *et al.*, in these reports

Masahiro KATOH (UVSOR Facility)

UVSOR Accelerator Complex

Injection Linear Accelerator

Energy	15 MeV
Length	2.5 m
Frequency	2856 MHz
Accelerating RF Field	$2\pi/3$ Traveling Wave
Klystron Power	1.8 MW
Energy Spread	~ 1.6 MeV
Repetition Rate	2.6 Hz

UVSOR-III Storage-Ring

Energy	750 MeV
Injection Energy	750 MeV
Maximum Storage Current	500 mA (multi bunch) 100 mA (single bunch)
Normal operation current	300 mA (multi bunch) (Top-up mode) 50 mA (single bunch)
Natural Emittance	17.5 nm-rad
Circumference	53.2 m
RF Frequency	90.1 MHz
Harmonic Number	16
Bending Radius	2.2 m
Lattice	Extended DBA $\times 4$
Straight Section	$(4\text{ m} \times 4) + (1.5\text{ m} \times 4)$
RF Voltage	120 kV
Betatron Tune	
Horizontal	3.75
Vertical	3.20
Momentum Compaction	0.030
Natural Chromaticity	
Horizontal	-8.1
Vertical	-7.3
Energy Spread	5.26×10^{-4}
Coupling Ratio	1%
Natural Bunch Length	128 ps

Booster Synchrotron

Energy	750 MeV
Injection	15 MeV
Frequency	32 mA (uniform filling)
Circumference	26.6 m
RF Frequency	90.1 MHz
Harmonic Number	8
Bending Radius	1.8m
Lattice	FODO $\times 8$
Betatron Tune	
Horizontal	2.25
Vertical	1.25
Momentum Compaction	0.138
Repetition Rate	1 Hz (750 MeV)

15 MeV
Linear
Accelerator

750 MeV
Booster
Synchrotron

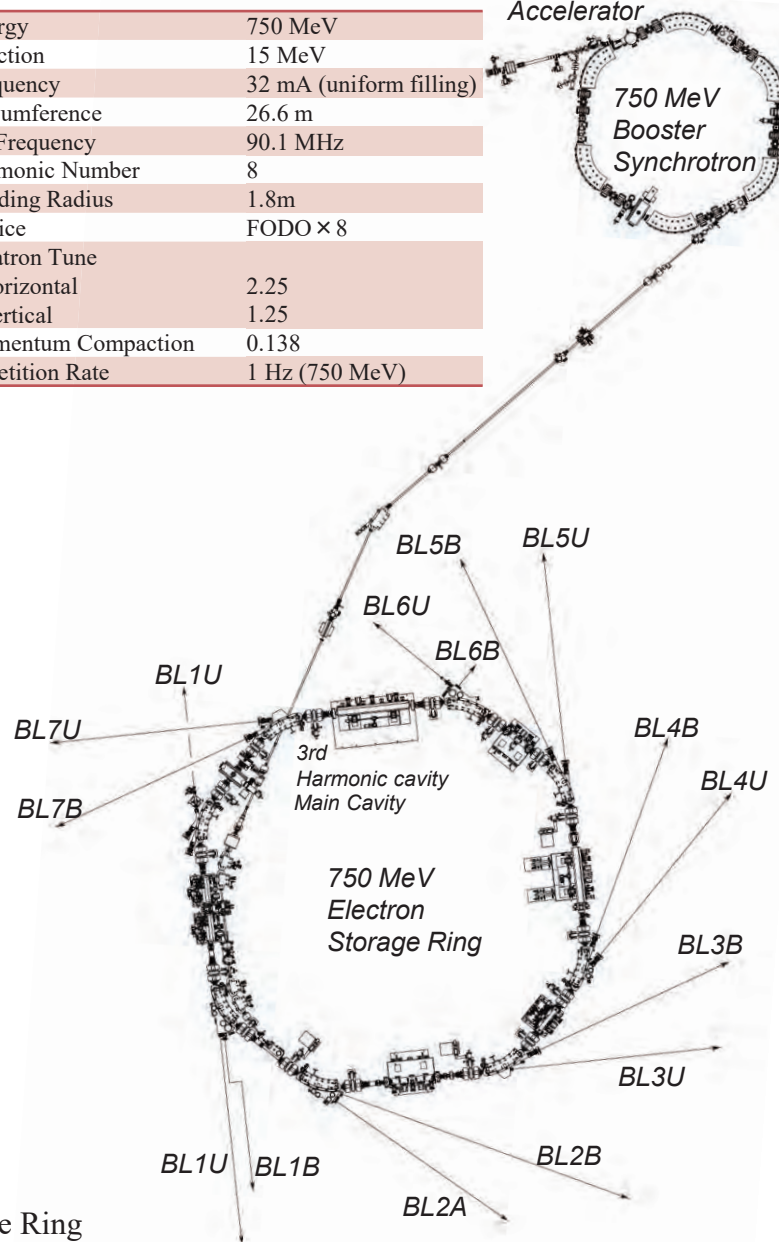

Electron Beam Optics of UVSOR-III Storage Ring

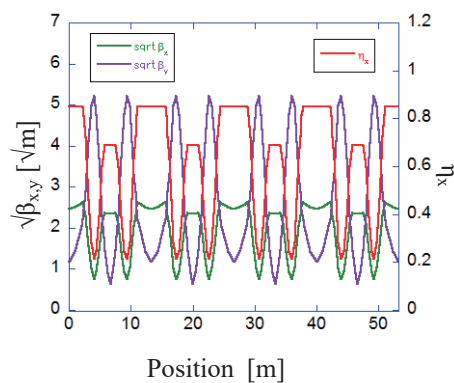

Horizontal/vertical betatron functions and dispersion function

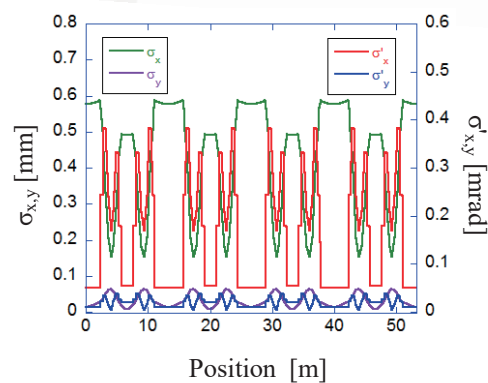

Horizontal/vertical electron beam size and beam divergences

Insertion Device

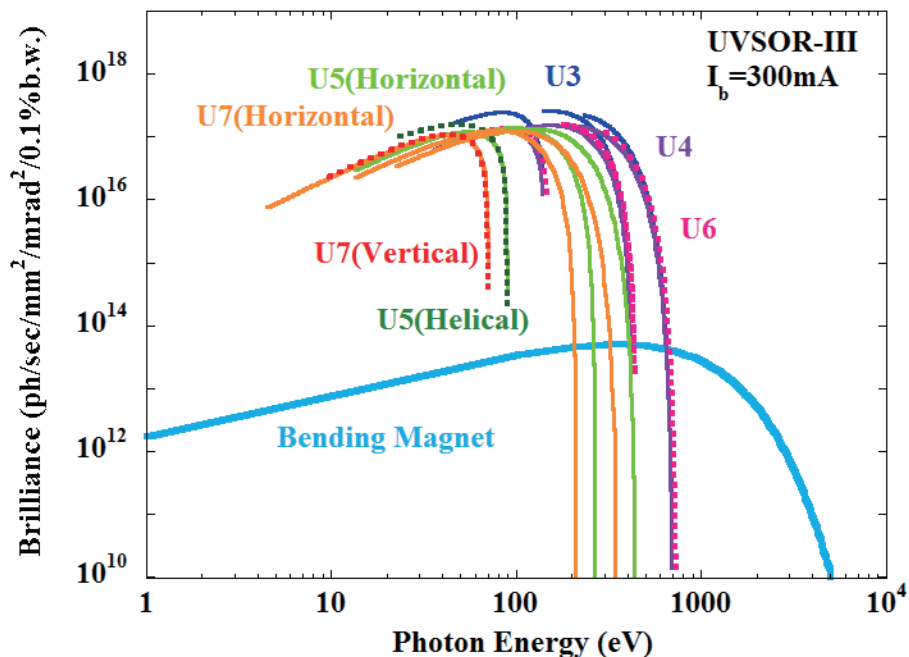

Brilliance of radiation from the insertion devices (U3, U4, U5, U6 and U7) and a bending magnet of UVSOR-III

U1 Apple-II Undulator /

Optical Klystron

Number of Periods	10+10
Period length	88 mm
Pole Length	0.968 m + 0.968 m
Pole Gap	24-200 mm
Deflection Parameter	7.36 (Max. Horizontal) 4.93 (Max. Vertical) 4.06 (Max. Helical)

U3 In-vacuum Undulator

Number of Periods	50
Period length	38 mm
Pole Length	1.9 m
Pole Gap	15-40 mm
Deflection Parameter	2.0-0.24

U4 In-vacuum Undulator

Number of Periods	26
Period length	38 mm
Pole Length	0.99 m
Pole Gap	13-40 mm
Deflection Parameter	2.4-0.19

U5 Apple-II

Variable Polarization Undulator

Number of Periods	38
Period length	60 mm
Pole Length	2.28 m
Pole Gap	24-190 mm
Deflection Parameter	3.4 (Max. Horizontal) 2.1 (Max. Vertical) 1.8 (Max. Helical)

U6 In-vacuum Undulator

Number of Periods	26
Period length	36 mm
Pole Length	0.94 m
Pole Gap	13-40 mm
Deflection Parameter	1.78 - 0.19

U7 Apple-II

Variable Polarization Undulator

Number of Periods	40
Period length	76 mm
Pole Length	3.04 m
Pole Gap	24-200 mm
Deflection Parameter	5.4 (Max. Horizontal) 3.6 (Max. Vertical) 3.0 (Max. Helical)

Bending Magnets

Bending Radius	2.2 m
Critical Energy	425 eV

Beamlines in 2016

Kiyohisa TANAKA

UVSOR Facility, Institute for Molecular Science

Among the synchrotron radiation facilities with electron energies of less than 1 GeV, UVSOR is one of the highest-brilliance light sources in the extreme-ultraviolet region. The natural emittance of the UVSOR-III storage ring is as low as 17.5 nm-rad after the successful completion of the storage ring upgrade project (the UVSOR-III project) in 2012.

Eight bending magnets and five insertion devices are available as synchrotron light sources at UVSOR. As of 2015 there are a total of fourteen operational beamlines, which are classified into two categories. Eleven of them are the so-called “Open beamlines”, which are open to scientists from universities and research institutes belonging to the government, public organizations, private enterprises and also those from foreign countries. The remaining three beamlines are the “In-house beamlines”, and are dedicated to the use of research groups within Institute for Molecular Science (IMS).

There is one soft X-ray station equipped with a double-crystal monochromator, seven extreme ultraviolet and soft X-ray stations with grazing incidence monochromators, three vacuum ultraviolet (VUV) stations with normal incidence monochromators, two infrared (IR) stations equipped with Fourier-Transform interferometers, and one free electron laser beamline with no monochromator, as shown in the appended table (next page) for all available beamlines at UVSOR in 2016.

In November 2016, there was a serious vacuum leakage accident from water cooling line at a four-quadrant copper mask located at upstream of BL3U. It was installed 10 years ago, and cooling water made a hole through 1 mm thick copper pipe. Since the accident occurred just after user operation, all upper most valves of beamlines were closed and the effect was limited to the storage ring. The whole storage ring has been baked after the four-quadrant copper mask was removed. User operation was restarted from 17th January, which means users lost beamtime for five weeks. The pipe which made leakage will be modified to 3 mm thickness one and will be installed during the shutdown of 2017. There are three more similar type of masks installed in the storage ring, and they will be also replaced during the shutdown. Users who lost beamtime were reassigned to the open beamtime

according to their request. If there was no beamtime left, users lost beamtime. The loss of beamtime will be considered during the peer review process of the next beamtime request in FY 2017. In BL4U, where there are many users from companies and minimum beamtime is one day, the rest of the whole beamtime was rescheduled.

BL2A equipped with a double-crystal monochromator, where users can use the highest energy photons in UVSOR (~4 keV), has been used mainly for photoabsorption spectroscopy. Since there are users who want to evaluate the sample surface, a new chamber for X-ray photoemission spectroscopy (XPS) has been prepared offline. This system will be attached to BL2A during the shutdown of 2017.

In BL3B, to achieve high efficiency VUV emission spectroscopy, a new endstation chamber has been designed and manufactured in 2016. It will be available from FY 2017.

BL6B is an Infrared-THz beamline which has confocal type micro-spectroscopy station, reflection/transmission station, and IR microscope imaging station. To solve serious long term drift of beam path caused by M0 magic mirror thermal load, the feedback control system of M0 mirror angle by monitoring the reflection of visible laser from M0 mirror has been developed. This feedback control system has been routinely operated and successfully provide stable beam for users from this year.

BL5U has been officially opened for users from 2016 as high energy resolution angle-resolved photoemission spectroscopy (ARPES) beamline. It became one of the most popular beamline in UVSOR, whose beamtime requests are about three times more than the beamtime. Space-resolved and spin-resolved function will be developed and installed in one year.

All users are required to refer to the beamline manuals and the UVSOR guidebook (the latest revision in PDF format uploaded on the UVSOR web site in June 2010), on the occasion of conducting the actual experimental procedures. Those wishing to use the open and in-house beamlines are recommended to contact the appropriate beamline master (see next page). For updated information on UVSOR, please see <http://www.uvsor.ims.ac.jp>.

Beamlines at UVSOR

Beamline	Monochromator / Spectrometer	Energy Range	Targets	Techniques	Contact
BL1U	Free electron laser	1.6 - 13.9 eV			M. Katoh mkatoh@ims.ac.jp
BL1B	Martin-Puplett FT-FIR	0.5 - 30 meV	Solid	Reflection Absorption	F. Teshima tetsu@ims.ac.jp
BL2A	Double crystal	585 eV - 4 keV	Solid	Reflection Absorption	N. Kondo nkondo@ims.ac.jp
BL2B	18-m spherical grating (Dragon)	23 - 205 eV	Solid	Photoemission	S. Kera kera@ims.ac.jp
BL3U*	Varied-line-spacing plane grating (Monk-Gillieson)	60 - 800 eV	Gas Liquid Solid	Absorption Photoemission Photon-emission	N. Kosugi kosugi@ims.ac.jp
BL3B	2.5-m off-plane Eagle	1.7 - 31 eV	Solid	Reflection Absorption Photon-emission	M. Hasumoto hasumoto@ims.ac.jp
BL4U	Varied-line-spacing plane grating (Monk-Gillieson)	130 - 700 eV	Gas Liquid Solid	Absorption (Microscopy)	T. Ohigashi ohigashi@ims.ac.jp
BL4B	Varied-line-spacing plane grating (Monk-Gillieson)	25 eV - 1 keV	Gas Solid	Photoionization Photodissociation Photoemission	E. Shigemasa sigemasa@ims.ac.jp
BL5U	Varied-line-spacing plane grating (Monk-Gillieson)	20 - 200 eV	Solid	Photoemission	M. Sakai sakai@ims.ac.jp
BL5B	Plane grating	6 - 600 eV	Solid	Calibration Absorption	M. Hasumoto hasumoto@ims.ac.jp
BL6U*	Variable-included-angle varied-line-spacing plane grating	40 - 800 eV	Gas Solid	Photoionization Photodissociation Photoemission	E. Shigemasa sigemasa@ims.ac.jp
BL6B	Michelson FT-IR	4 meV - 2.5 eV	Solid	Reflection Absorption IR microscope	F. Teshima tetsu@ims.ac.jp
BL7U	10-m normal incidence (modified Wadsworth)	6 - 40 eV	Solid	Photoemission	S. Ideta idetas@ims.ac.jp
BL7B	3-m normal incidence	1.2 - 25 eV	Solid	Reflection Absorption Photon-emission	M. Hasumoto hasumoto@ims.ac.jp

Yellow columns represent undulator beamlines.

* In-house beamline.

BL1U

Light Source Development Station

▼ Description

BL1U has been constructed for developments and applications of various photon sources including free electron laser in the range from visible to deep UV, coherent harmonic generation in the deep UV and VUV, laser Compton scattering gamma-rays and undulator radiation with various polarization properties including optical vortices.

The beam-line is equipped with a dedicated twin polarization variable undulator system with a buncher section, which can be used for a FEL oscillator and a VUV CHG. It is also equipped with a femto-second laser system synchronized with the accelerator, which is used for CHG, slicing, LCS and coherent THz radiation generation.

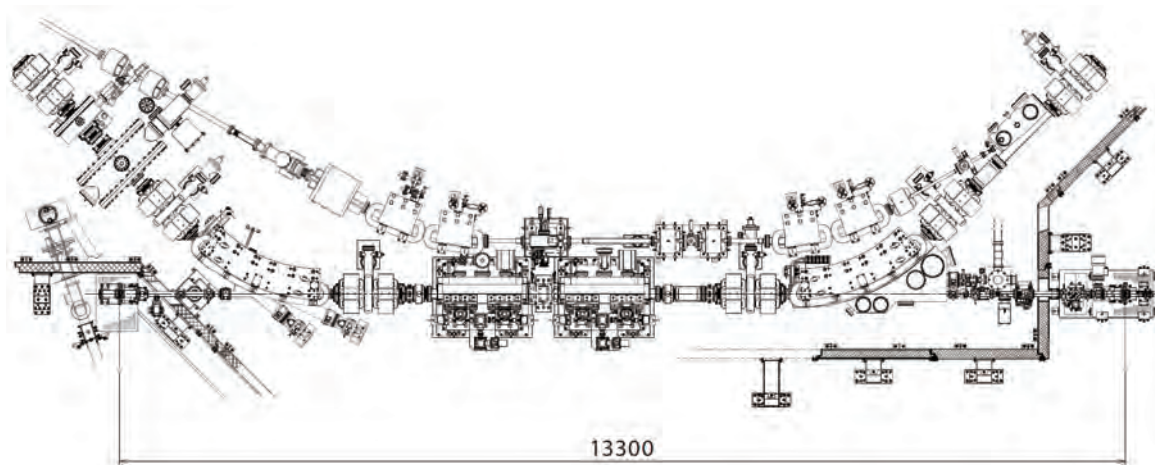

Fig. 1. Configuration of the free electron laser (under reconstruction)

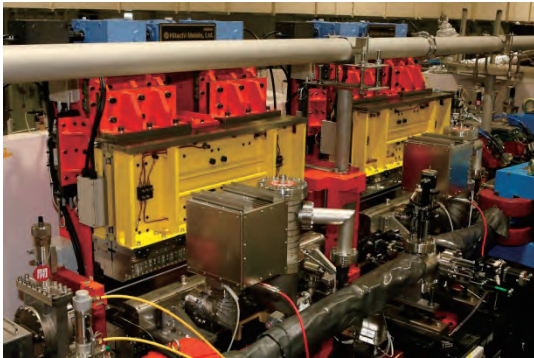

Fig. 2. Twin Apple-II Undulator

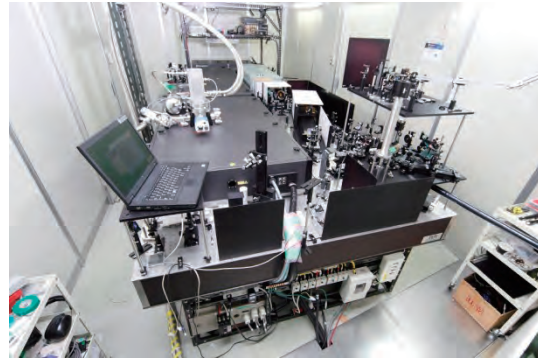

Fig. 3. Accelerator Synchronized Laser System

▼ Technical Data of FEL

Wave Length	199-800 nm
Spectral Band Width	$\sim 10^{-4}$
Polarization	Circular/Linear
Pulse Rate	11.26 MHz
Max. Ave. Power	$\sim 1W$

▼ Technical Data of Ti:Sa Laser

Wave Length	800 nm
Pulse Length	130 fsec
Oscillator	90.1 MHz
Pulse Energy	2.5mJ 10mJ 50mJ
Repetition Rate	1kHz 1kHz 10Hz

BL1B

Terahertz Spectroscopy Using Coherent Synchrotron Radiation

II

▼ Description

Coherent synchrotron radiation (CSR) is a powerful light source in the terahertz (THz) region. This beamline has been constructed for basic studies on the properties of THz-CSR. However, it can be also used for measurements of reflectivity and transmission spectra of solids using conventional synchrotron radiation.

The emitted THz light is collected by a three-dimensional magic mirror (3D-MM, M0) of the same type as those already successfully installed at BL43IR in SPring-8 and BL6B in UVSOR-II. The 3D-MM was installed in bending-magnet chamber #1 and is controlled by a 5-axis pulse motor stage (x, z translation; θ_x , θ_y , θ_z rotation). The acceptance angle was set at 17.5-34 degrees (total 288 mrad) in the horizontal direction. The vertical angle was set at ± 40 mrad to collect the widely expanded THz-CSR.

The beamline is equipped with a Martin-Puplett type interferometer (JASCO FARIS-1) to cover the THz spectral region from 4 to 240 cm^{-1} ($h\nu = 500 \mu\text{eV}$ -30 meV). There is a reflection/absorption spectroscopy (RAS) end-station for large samples (\sim several mm). At the RAS end-station, a liquid-helium-flow type cryostat with a minimum temperature of 4 K is installed.

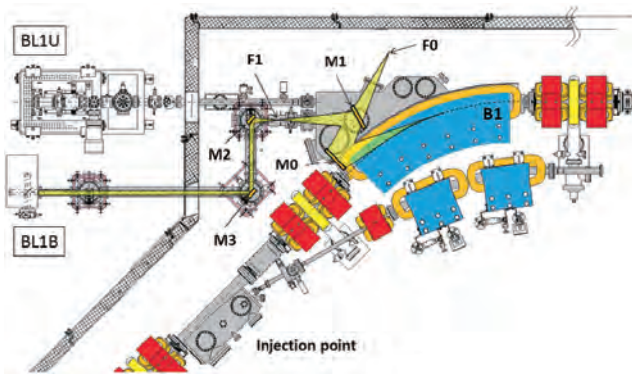

Fig. 1. Schematic top view of the beam extraction part of the THz-CSR beamline, BL1B. The three-dimensional magic mirror (3D-MM, M0) and a plane mirror (M1) are located in the bending-magnet chamber. A parabolic mirror (M2) is installed to form a parallel beam. The straight section (BL1U) is used for coherent harmonic generation (CHG) in the VUV region.

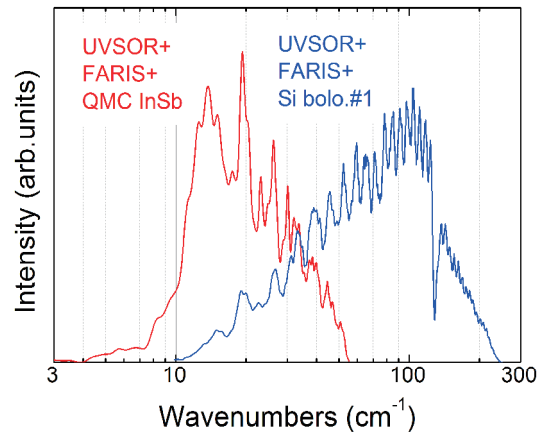

Fig. 2. Obtained intensity spectra with the combination of a light source (UVSOR), interferometer (FARIS-1), and detectors (Si bolometer and InSb hot-electron bolometer).

▼ Technical Data

Interferometer	Martin-Puplett (JASCO FARIS-1)
Wavenumber range	4-240 cm^{-1}
(Energy range)	(500 μeV -30 meV)
Resolution in cm^{-1}	0.25 cm^{-1}
Experiments	Reflection/transmission spectroscopy
Miscellaneous	Users can use their experimental system in this beamline.

BL2A

Soft X-Ray Beamline for Photoabsorption Spectroscopy

▼ Description

BL2A, which was moved its previous location as BL1A in 2011, is a soft X-ray beamline for photoabsorption spectroscopy. The beamline is equipped with a focusing premirror and a double-crystal monochromator [1]. The monochromator serves soft X-rays in the energy region from 585 to 4000 eV using several types of single crystals, such as β -Al₂O₃, beryl, KTP (KTiOPO₄), quartz, InSb, and Ge. The throughput spectra measured using a Si photodiode (AXUV-100, IRD Inc.) are shown in Fig. 1. The typical energy resolution ($E / \Delta E$) of the monochromator is approximately 1500 for beryl and InSb.

A small vacuum chamber equipped with an electron multiplier (EM) detector is available. Photoabsorption spectra for powdery samples are usually measured in total electron yield mode, with the use of the EM detector. A silicon drift detector is also available for measuring partial fluorescence yields from solid samples.

[1] Hiraya *et al.*, Rev. Sci. Instrum. **63** (1992) 1264.

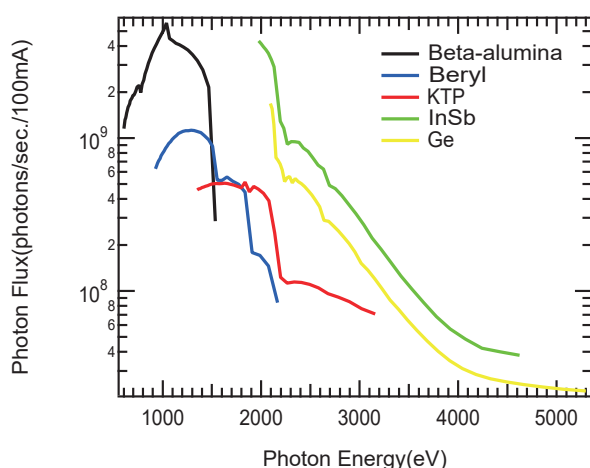

Fig. 1. Throughput spectra of the double-crystal monochromator at BL2A.



Fig. 2. Side view of BL2A.

▼ Technical Data

Monochromator	Double crystal monochromator
Monochromator crystals: (2 θ value, energy range)	β -Al ₂ O ₃ (22.53 \AA , 585-1609 eV), beryl (15.965 \AA , 826-2271 eV), KTP (10.95 \AA , 1205-3310 eV), quartz (8.512 \AA , 1550-4000 eV), InSb (7.481 \AA , 1764-4000 eV), Ge (6.532 \AA , 2094-4000 eV)
Resolution	$E / \Delta E = 1500$ for beryl and InSb
Experiments	Photoabsorption spectroscopy (total electron yield using EM and partial fluorescence yield using SDD)

BL2B

Photoelectron spectroscopy of molecular solids

II

▼ Description

This beamline previously dedicated for experiments in the field of gas phase photoionization and reaction dynamics. Then, the beamline has been reconstructed for photoelectron spectroscopy of molecular solids with a new end station, and experiments can be performed from May 2014. The monochromator is a spherical grating Dragon type with 18-m focal length. High throughput (1×10^{10} photons s^{-1}) and high resolution ($E/\Delta E = 2000 - 8000$) are achieved simultaneously under the condition of the ring current of 100 mA [1]. The optical system consists of two pre-focusing mirrors, an entrance slit, three spherical gratings (G1 - G3), two folding mirrors, a movable exit slit, and a refocusing mirror [2]. The monochromator is designed to cover the energy range of 23–205 eV with the three gratings: G1 (2400 lines mm^{-1} , $R = 18$ m) at 80–205 eV; G2 (1200 lines mm^{-1} , $R = 18$ m) at 40–100 eV; G3 (2400 lines mm^{-1} , $R = 9.25$ m) at 23–50 eV. The percentage of the second-order light contamination at $h\nu = 45.6$ eV is 23% for G2 or 7% for G3.

A UHV chamber is placed downstream of the refocusing mirror chamber and equipped silicon photodiode, sapphire plate Au mesh and filters for absolute photon flux measurement, monitor the photon-beam position, relative photon flux measurements and attenuate higher order light, respectively.

The new end station consists of a main chamber with a hemispherical analyzer (SCIENTA R3000) and a liquid-He-cooled cryostat (temperature range of 15-400 K) with 5-axis stage, a sample preparation chamber with a fast-entry load-lock chamber and a cleaning chamber with LEED, ion gun for sputtering and IR heating unit.

[1] M. Ono, H. Yoshida, H. Hattori and K. Mitsuke, Nucl. Instrum. Meth. Phys. Res. A **467-468** (2001) 577.

[2] H. Yoshida and K. Mitsuke, J. Synchrotron Radiation **5** (1998) 774.

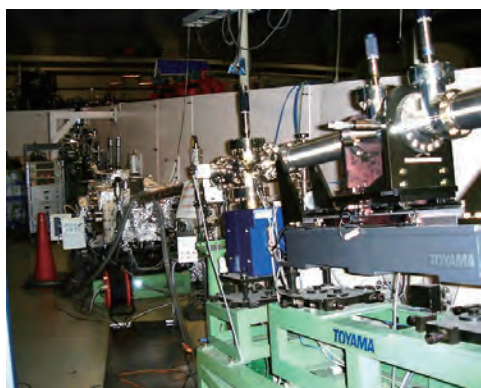

Fig. 1. 18 m spherical grating monochromator at BL2B.

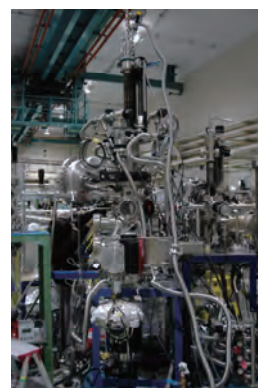

Fig. 2. End station of BL2B for photoelectron spectroscopy of molecular solids.

▼ Technical Data

Monochromator	18 m spherical grating Dragon-type
Wavelength Range	23-205 eV
Resolution	2000-8000 depending on the gratings
Experiments	Angle-resolved ultraviolet photoemission spectroscopy

BL3U

Varied-Line-Spacing Plane Grating Monochromator for Molecular Soft X-Ray Spectroscopy

▼ Description

The beamline BL3U is equipped with an in-vacuum undulator composed of 50 periods of 3.8 cm period length. The emitted photons are monochromatized by the varied-line-spacing plane grating monochromator (VLS-PGM) designed for various spectroscopic investigations in the soft X-ray range including soft X-ray emission studies. Three holographically ruled laminar profile plane gratings are designed to cover the photon energy range from 60 to 800 eV. The beamline has two endstations, namely, XES setup and multi-purpose setup. The XES setup is used for soft X-ray emission spectroscopy. The beam is horizontally focused onto the sample position by a plane-elliptical mirror, M2X. In the multi-purpose setup, the beam is focused by the toroidal mirror M2. Between the sample position and M2, the differential pumping is placed. XAS of liquid samples and the application of in operando observations are performed at the experimental stage of the multi-purpose setup.

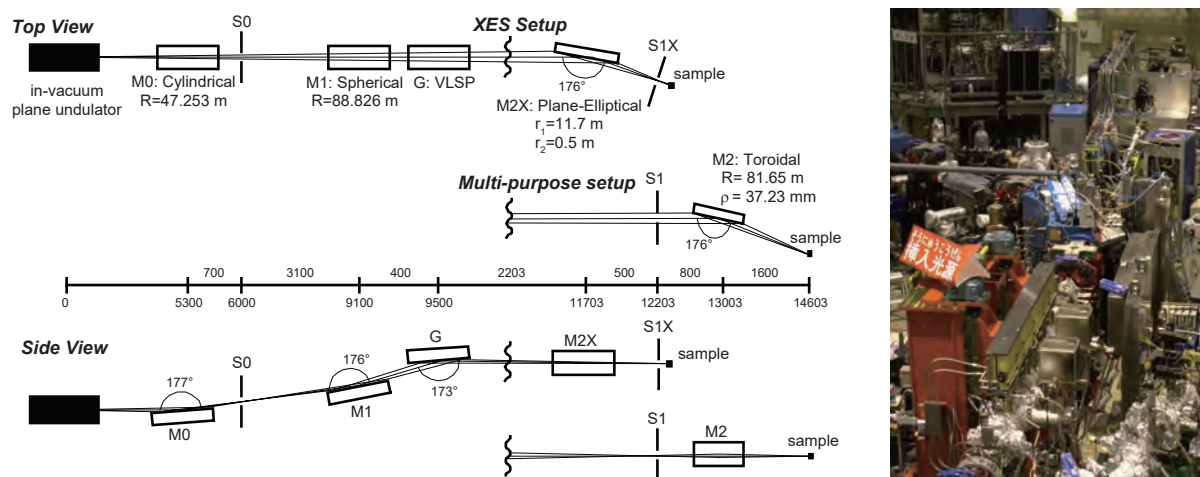

Fig. 1. Schematic layout (left) and the photography (right) of the BL3U. The distances along the beam from the center of the in-vacuum plane undulator are shown in millimeters. S1X and M2X can be replaced with the other exit slit S1 so that experiments can be carried out at either the XES or the multipurpose endstation. In the XES setup, the sample is placed 5–10 mm downstream of S1X.

▼ Technical Data

Monochromator	Varied-line-spacing plane grating monochromator
Energy Range	60-800 eV
Resolution	$E / \Delta E > 10\,000$
Experiments	Soft X-ray spectroscopy (XPS, XES, XAS)
Beam Size (XES Endstation)	Gaussian shape Vertical 5-20 μm ; Horizontal 41 μm (FWHM)

BL3B (HOTRLU)

VIS-VUV Photoluminescence and Reflection/Absorption Spectroscopy

▼ Description

BL3B has been constructed to study photoluminescence (PL) in the visible (VIS) to vacuum ultraviolet (VUV) region. This beamline consists of a 2.5 m off-plane Eagle type normal-incidence monochromator, which covers the VUV, UV, and VIS regions, i.e., the energy (wavelength) region of 1.7-31 eV (40-730 nm), with three spherical gratings having constant grooving densities of 1200, 600, and 300 l/mm optimized at the photon energies of ~ 20 , ~ 16 , and ~ 6 eV, respectively. The schematic side view and top view layouts are shown in Figs. 1(a) and 1(b), respectively. The FWHM of the beam spot at the sample position is 0.25 mm (V) \times 0.75 mm (H). Low energy pass filters (LiF, quartz, WG32, OG53) can be inserted automatically to maintain the optical purity in the G3 (300 l/mm) grating region (1.7–11.8 eV). Figure 2 shows the throughput spectra (photon numbers at a beam current of 300 mA) for each grating with entrance and exit slit openings of 0.1 mm (resolving power $E / \Delta E$ of ~ 2000 (G3, ~ 6.8 eV)). Since both slits can be opened up to 0.5 mm, a monochromatized photon flux of 10^{10} photons/s or higher is available for PL measurements in the whole energy region.

The end station is equipped with a liquid-helium-flow type cryostat for sample cooling and two detectors; one of which is a photomultiplier with sodium salicylate and the other a Si photodiode for reflection/absorption measurement. For the PL measurements in the wide energy region from VIS to VUV, two PL monochromators, comprising not only a conventional VIS monochromator but also a VUV monochromator with a CCD detector, are installed at the end station.

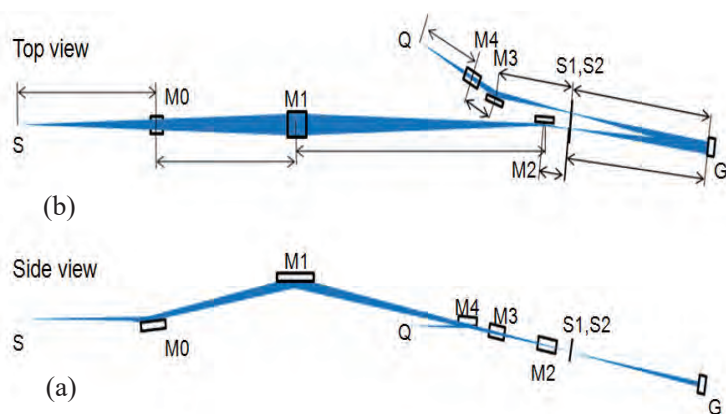

Fig. 1. Schematic layout of the BL3B (a) side view and (b) top view.

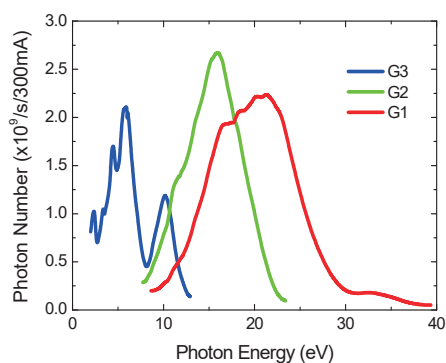

Fig. 2. Throughput spectra for each grating (G1:1200 l/mm, G2:600 l/mm and G3:300 l/mm) with $S1 = S2 = 0.1$ mm.

▼ Technical Data

Monochromator	-2.5 m normal-incidence monochromator
Energy range	1.7-31 eV (40-730 nm)
Resolution ($\Delta h\nu / h\nu$)	≥ 12000 (at ~ 6.9 eV, 0.02 mm slits, G1 (1200 l/mm))
Experiments	Photoluminescence, reflection, and absorption spectroscopy, mainly for solids

BL4U

Scanning Transmission X-ray Microscopy in the Soft X-ray Region

▼ Description

In the soft x-ray region, there are several absorption edges of light elements and transition metals. The near edge X-ray absorption fine structure (NEXAFS) brings detailed information about the chemical state of target elements. A scanning transmission X-ray microscope (STXM) in the soft X-ray region is a kind of extended technique of the NEXAFS with high spatial resolution. The STXM has a capability of several additional options, for example, in-situ observations, 3-dimensional observation by computed tomography and ptychography, by utilizing the characteristics of the X-rays. The STXM can be applied to several sciences, such as polymer science, material science, cell biology, environmental science, and so on.

This beamline equips an in-vacuum undulator, a varied-line-spacing plane grating monochromator and a fixed exit slit. The soft X-ray energy range from 100 to 770 eV with the resolving power ($E/\Delta E$) of 6,000 is available. The aperture size of the fixed exit slit determines not only the resolving power but also the size of a microprobe. A Fresnel zone plate is used as a focusing optical device through an order select aperture and its focal spot size of ~ 30 nm is available at minimum. An image is acquired by detecting intensities of the transmitted X-rays by a photomultiplier tube with scintillator with scanning a sample 2-dimensionally. By changing the energy of the incident beam, each 2-dimensional NEXAFS image is stacked. A main chamber of STXM is separated from the beamline optics by a silicon nitride membrane of 100-nm thickness; therefore, sample folders can be handled in vacuum or in helium.

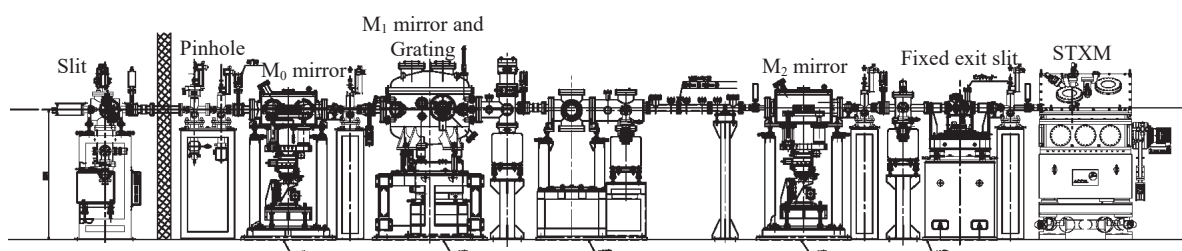

Fig. 1. Schematic image of BL4U

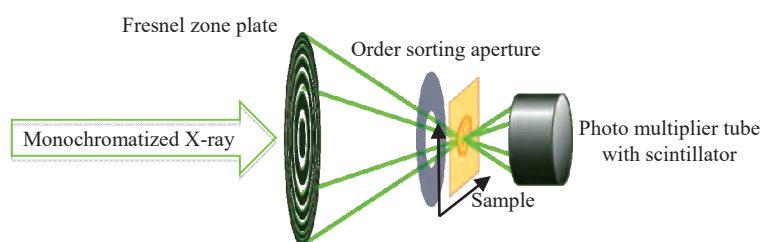

Fig. 2. Schematic image of the STXM

▼ Technical Data

Energy range (E)	100-770 eV
Resolving power ($E/\Delta E$)	$\sim 6,000$
Focusing optical element	Fresnel zone plate
Spatial resolution	~ 30 nm
Experiments	2-dimensional absorption spectroscopy
Measurement environment	standard sample folder in vacuum or in helium, specially designed sample cell in ambient condition

BL4B

Varied-Line-Spacing Plane Grating Monochromator for Molecular Soft X-Ray Spectroscopy

▼ Description

The beamline BL4B equipped with a varied-line-spacing plane grating monochromator (VLS-PGM) was constructed for various spectroscopic investigations in a gas phase and/or on solids in the soft X-ray range. Three holographically ruled laminar profile plane gratings with SiO₂ substrates are designed to cover the photon energy range from 25 to 800 eV. The gratings with groove densities of 100, 267, and 800 1/mm cover the spectral ranges of 25–100, 60–300, and 200–1000 eV, respectively, and are interchangeable without breaking the vacuum. Fig. 1 shows the absolute photon flux for each grating measured using a Si photodiode (IRD Inc.), with the entrance- and exit-slit openings set at 50 and 50 μm, respectively. The maximum resolving power ($E/\Delta E$) achieved for each grating exceeds 5000.

There is no fixed endstation on this beamline. A small vacuum chamber equipped with an electron multiplier (EM) detector is available. Soft X-ray absorption spectra of solid samples are usually measured by means of the total electron yield method using EM, and the partial fluorescence yield method using a silicon drift detector (SDD).

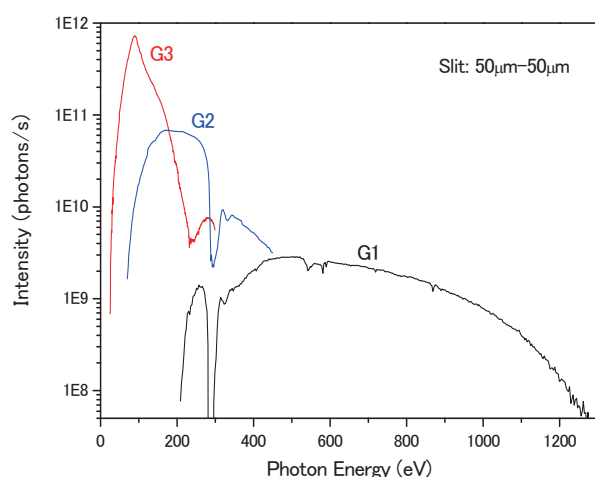

Fig. 1. Throughput from the VLS-PGM monochromator on BL4B.

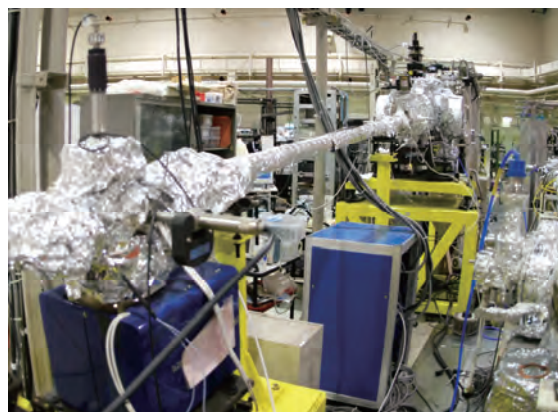

Fig. 2. Photo of BL4B.

▼ Technical Data

Monochromator	Varied-line-spacing Plane Grating Monochromator
Energy range	25-1000 eV
Resolution	$E / \Delta E > 5000$ (at maximum)
Experiments	Soft X-ray spectroscopy (mainly, photoabsorption spectroscopy for solid targets by means of total electron yield method using EM and partial fluorescence yield method using SDD)

BL5U

Photoemission Spectroscopy of Solids and Surfaces

▼ Description

This beamline was originally used for angle-resolved photoemission spectroscopy (ARPES) study of solids and surfaces. After Jan 2014, the beamline had been shutdown for upgrade. The whole beamline, including the undulator and the endstation, is renewed to perform higher energy resolution ARPES experiments. This beamline will also have new capability to obtain spin- and spatial-dependence of the electronic structure of solids using new spin detector and micro-focused beam. This beamline is opened for users from 2016.

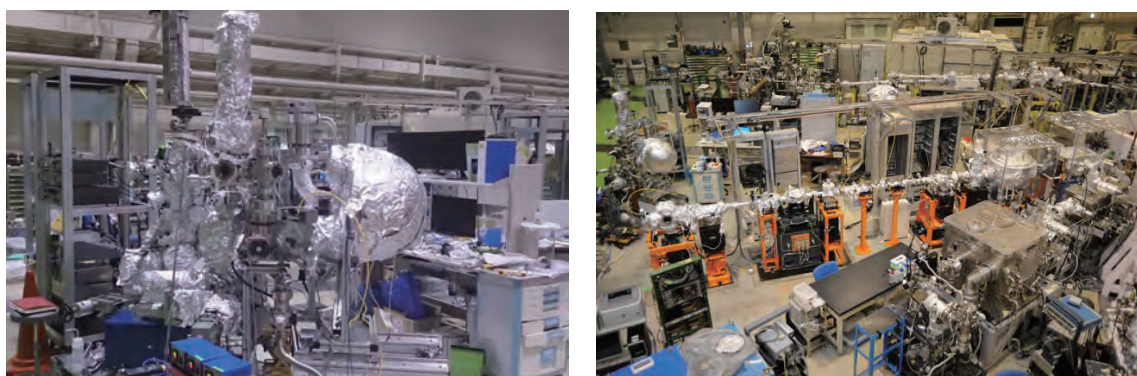

Fig. 1. Pictures of BL5U on May 2014.

▼ Technical Data (Expected Performance)

Monochromator	Monk-Gillieson VLS-PGM
Energy Range	20-200 eV
Resolution	$h\nu / \Delta E > 10,000$ for $< 10 \mu\text{m}$ slits
Experiment	ARPES, Spin-resolved ARPES, Space-resolved ARPES
Flux	$< 10^{12}$ photons/s for $< 10 \mu\text{m}$ slits (at the sample position)
Beam spot size	400 (H) x 5-20 (V) μm , 10 (H) x 4-6 (V) μm (microscope)
Main Instruments	Hemispherical photoelectron analyzer (MBS A-1), Liq-He flow cryostat with 5-axis manipulator (5-400 K)

BL5B

Calibration Apparatus for Optical Elements and Detectors

II

▼ Description

BL5B has been constructed to perform calibration measurements for optical elements and detectors. This beamline is composed of a plane grating monochromator (PGM) and three endstations in tandem. The most upstream station is used for the calibration measurements of optical elements, the middle one for optical measurements for solids, and the last for photo-stimulated desorption experiments. The experimental chamber at the most downstream station is sometimes changed to a chamber for photoemission spectroscopy. The calibration chamber shown in Fig. 2 is equipped with a goniometer for the characterization of optical elements, which has six degrees of freedom, X-Y translation of a sample, and interchanging of samples and filters. These are driven by pulse motors in vacuum. Because the polarization of synchrotron radiation is essential for such measurements, the rotation axis can be made in either the horizontal or vertical direction (s- or p-polarization).

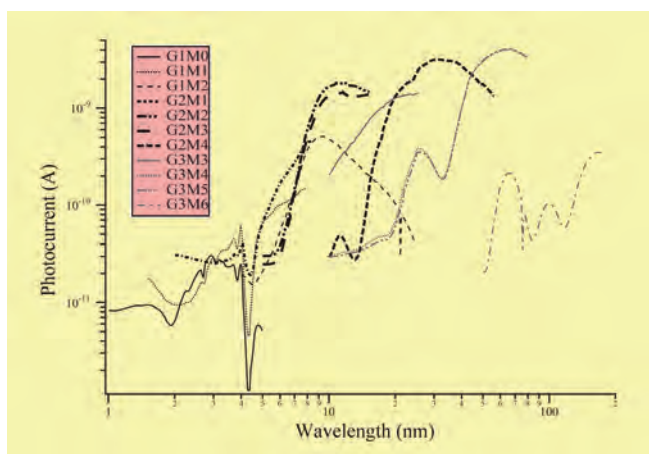

Fig. 1. Throughput spectra for possible combinations of gratings and mirrors at BL5B measured by a gold mesh.

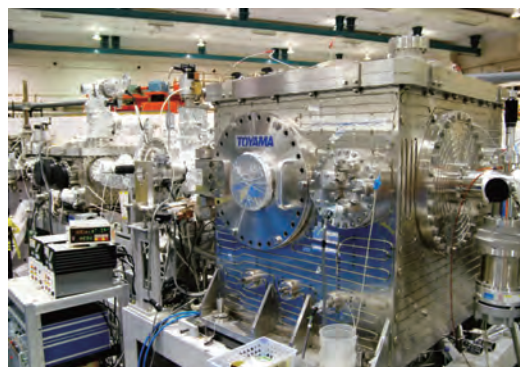

Fig. 2. A side view of the experimental chamber for calibration measurements.

▼ Technical Data

Monochromator	Plane Grating Monochromator
Energy range	6-600 eV (2-200 nm)
Resolution	$E / \Delta E \sim 500$
Experiments	Calibration of optical elements, reflection and absorption spectroscopy mainly for solids

BL6U

Variable-Included-Angle VLS-PGM for Molecular Soft X-Ray Spectroscopy

▼ Description

The beamline BL6U equipped with a variable-included-angle Monk-Gillieson mounting monochromator with a varied-line-spacing plane grating was constructed for various spectroscopic investigations requiring high-brilliance soft X-rays in a gas phase and/or on solids. Through a combination of undulator radiation and sophisticated monochromator design (entrance slit-less configuration and variable-included-angle mechanism), using a single grating, the monochromator can cover the photon energy ranging from 30 to 500 eV, with resolving power of greater than 10000 and photon flux of more than 10^{10} photons/s. Figure 1 shows an example of the monochromator throughput spectra measured using a Si photodiode, with the exit-slit opening set at 30 μm , which corresponds to the theoretical resolving power of 10000 at 80 eV.

There is no fixed endstation on this beamline.

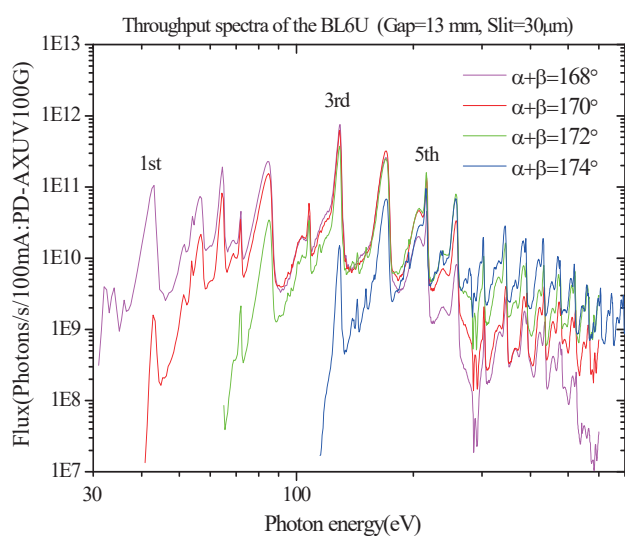

Fig. 1. Throughput spectra of the BL6U monochromator at various included angles.

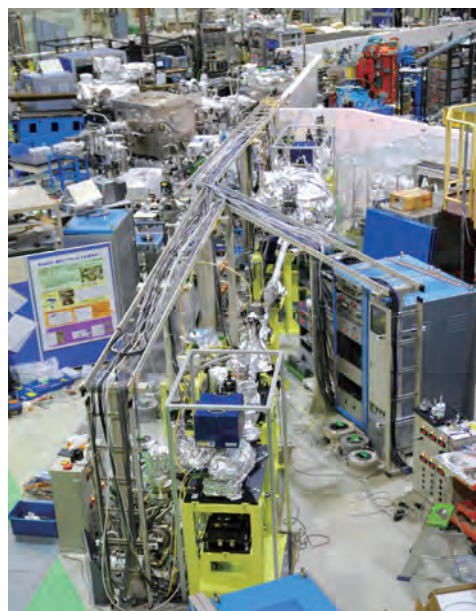

Fig. 2. Photo of BL6U

▼ Technical Data

Monochromator	Variable-included-angle Varied-line-spacing Plane Grating Monochromator
Energy range	40-500 eV
Resolution	$E / \Delta E > 10000$ (at maximum)
Experiments	High-resolution soft X-ray spectroscopy (mainly photoelectron spectroscopy for gaseous and solid targets)

BL6B

Infrared and Terahertz Spectroscopy of Solids

II

▼ Description

Synchrotron radiation (SR) has good performance (high brilliance and high flux) not only in the VUV and soft X-ray (SX) regions but also in the infrared (IR) and THz regions. BL6B covers the IR and THz regions. The previous beamline, BL6A1, which was constructed in 1985, was the pioneer in IRSR research. The beamline was deactivated at the end of FY2003 and a new IR/THz beamline, BL6B (IR), was constructed in FY2004. The front-end part including bending duct #6 was replaced with a new part having a higher acceptance angle ($215 \text{ (H)} \times 80 \text{ (V)} \text{ mrad}^2$) using a magic mirror, as shown in Fig. 1.

There are two Michelson type interferometers in this endstation; with first one (Bruker Vertex70v), which covers a wide spectral region from 30 to 20,000 cm^{-1} ($h\nu = 4 \text{ meV} - 2.5 \text{ eV}$), reflection/absorption spectroscopy measurements of large samples (up to several mm) and IR/THz microscopy measurements of tiny samples (up to several tens of μm) can be performed. For reflection/absorption spectroscopy measurements, a liquid-helium-flow type cryostat with a minimum temperature of 4 K is installed. The other interferometer (Jasco FT/IR-6100), which covers 350 to 15,000 cm^{-1} ($h\nu = 45 \text{ meV} - 1.8 \text{ eV}$), has been available for IR microscopy imaging measurements from FY2014. One can also perform ATR measurements using diamond ATR prism.

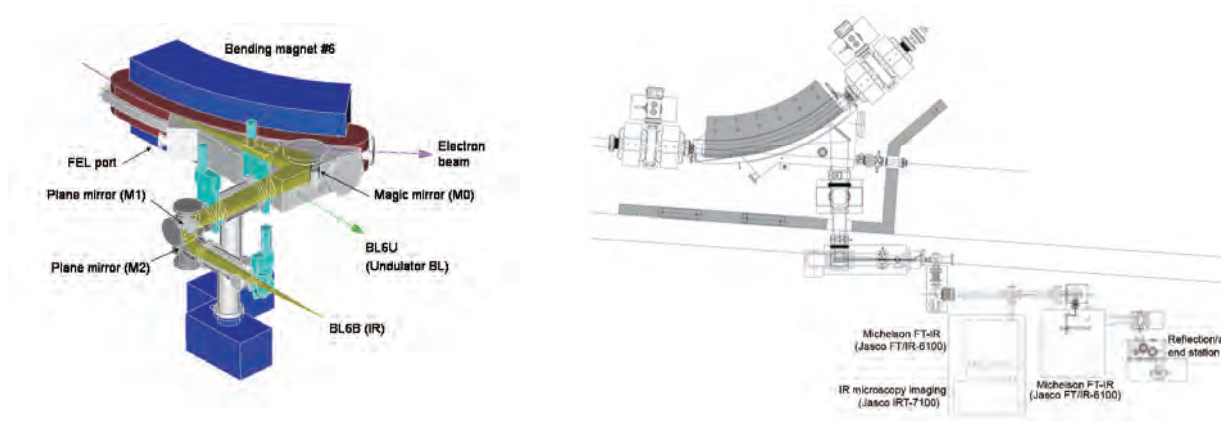

Fig. 1. Design of the optics and front end of BL6B. Fig. 2. Schematic top view of BL6B.

▼ Technical Data

Interferometer	Michelson (Bruker Vertex70v)	Michelson (Jasco FT/IR-6100)
Wavenumber Range (Energy range)	30-20,000 cm^{-1} (4 meV-2.5 eV)	350-15,000 cm^{-1} (45 meV-1.8 eV)
Resolution in cm^{-1}	0.1 cm^{-1}	0.5 cm^{-1}
Experiments	Reflectivity and transmission spectroscopy THz Microspectroscopy	IR microscopy imaging (JASCO IRT-7000) ATR spectroscopy

BL7U (SAMRAI)

Angle-Resolved Photoemission of Solids in the VUV Region

▼ Description

Beamline 7U, named the Symmetry- And Momentum-Resolved electronic structure Analysis Instrument (SAMRAI) for functional materials, was constructed to provide a photon flux with high energy resolution and high flux mainly for high-resolution angle-resolved photoemission spectroscopy, so-called “ARPES”, of solids [1]. An APPLE-II-type variable-polarization undulator is installed as the light source. The undulator can produce intense VUV light with horizontal/vertical linear and right/left circular polarization. The undulator light is monochromatized by a modified Wadsworth type monochromator with three gratings (10 m radius; 1200, 2400, and 3600 lines/mm optimized at $h\nu = 10, 20, \text{ and } 33 \text{ eV}$). The energy resolution of the light ($h\nu/\Delta h\nu$ is more than 10^4 with a photon flux of 10^{11} - 10^{12} ph/s or higher on samples in the entire energy region. The beamline has a photoemission end-station equipped with a 200 mm-radius hemispherical photoelectron analyzer (MB Scientific AB, A-1 analyzer) with a wide-angle electron lens and a liquid-helium-cooled cryostat with 6-axis pulse motor control (AVC Co., Ltd., i-GONIO). The main function of the beamline is to determine the electronic structure of solids and its temperature dependence in order to reveal the origin of their physical properties.

[1] S. Kimura, T. Ito, M. Sakai, E. Nakamura, N. Kondo, K. Hayashi, T. Horigome, M. Hosaka, M. Katoh, T. Goto, T. Ejima and K. Soda, Rev. Sci. Instrum. **81** (2010) 053104.

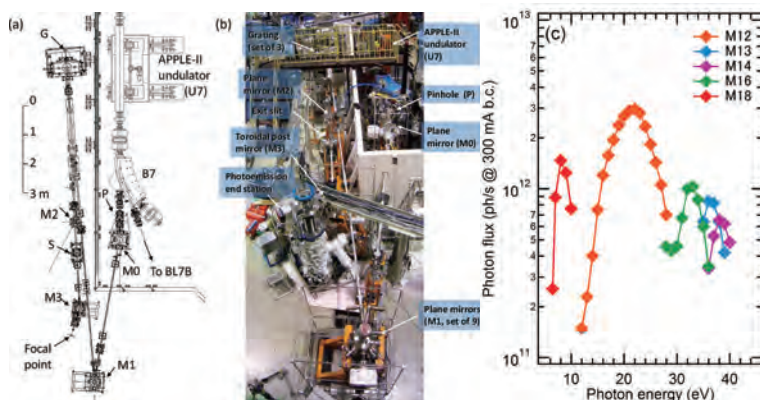

Fig. 1. SAMRAI beamline [(a), (b)] consisting of an APPLE-II type undulator (U7), a modified Wadsworth type monochromator (M0-S), and a high-resolution photoemission analyzer at the focal point. The monochromator has five major optical components: two plane mirrors (M0 and M1) with water cooling, one set of three spherical gratings (G), an exit slit (S), and one toroidal refocusing mirror (M3). (c) Example of flux intensity *versus* photon energy [1].

▼ Technical Data

Light source	APPLE-II type undulator ($\lambda_u = 76 \text{ mm}$, $N = 36$) vertical/horizontal, right/left circular (depending on $h\nu$)
Monochromator	10 m normal-incidence monochromator (modified Wadsworth type)
Photon energy range	6-40 eV ($\lambda = 30$ -200 nm)
Resolution ($h\nu/\Delta h\nu$)	$E / \Delta E > 10000$ -50000
Photon flux on sample	$\geq 10^{12}$ - 10^{11} ph/s (depending on $h\nu$)
Beam size on sample	$200 \text{ (H)} \times 50 \text{ (V)} \mu\text{m}^2$
Experiments	Angle-resolved photoemission of solids (MV Scientific A-1 analyzer, acceptance angle: $\pm 18 \text{ deg}$)

BL7B

3 m Normal-Incidence Monochromator for Solid-State Spectroscopy

II

▼ Description

BL7B has been constructed to provide sufficiently high resolution for conventional solid-state spectroscopy, sufficient intensity for luminescence measurements, wide wavelength coverage for Kramers–Kronig analyses, and minimum deformation to the polarization characteristic of incident synchrotron radiation. This beamline consists of a 3-m normal incidence monochromator, which covers the vacuum ultraviolet, ultraviolet, visible, and infrared, i.e., the wavelength region of 50–1000 nm, with three gratings (1200, 600, and 300 1/mm). Two interchangeable refocusing mirrors provide two different focusing positions. For the mirror with the longer focal length, an LiF or a MgF₂ window valve can be installed between the end valve of the beamline and the focusing position. Figure 1 shows the absolute photon intensity for each grating with the entrance and exit slit openings of 0.5 mm. A silicon photodiode (AXUV-100, IRD Inc.) was utilized to measure the photon intensity and the absolute photon flux was estimated, taking the quantum efficiency of the photodiode into account.

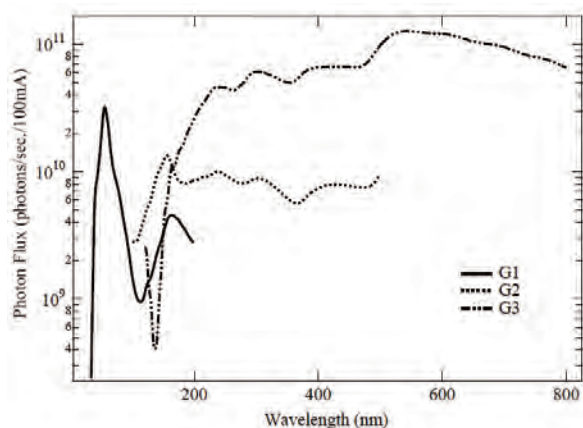

Fig. 1. Throughput spectra of BL7B measured using a silicon photodiode.

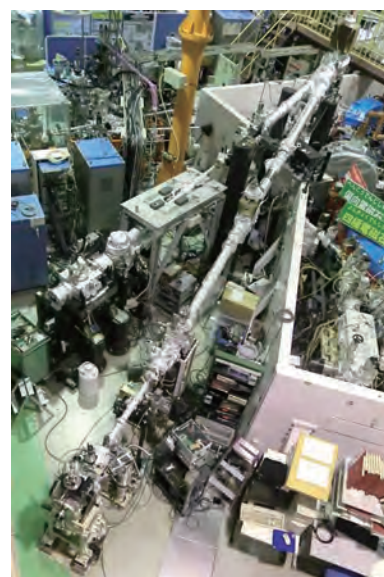
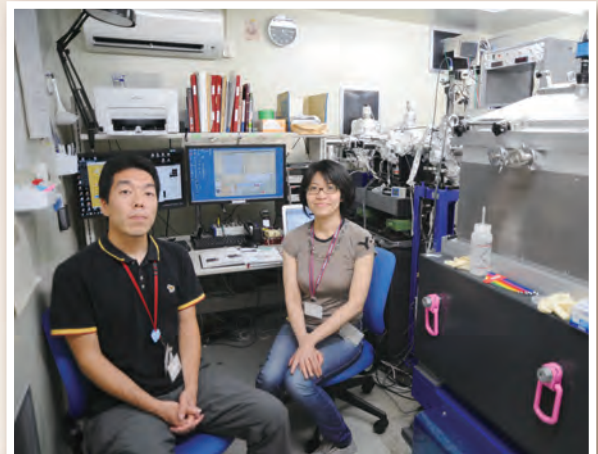
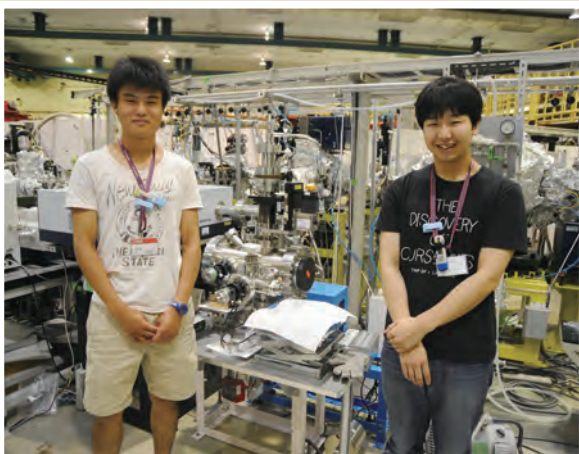
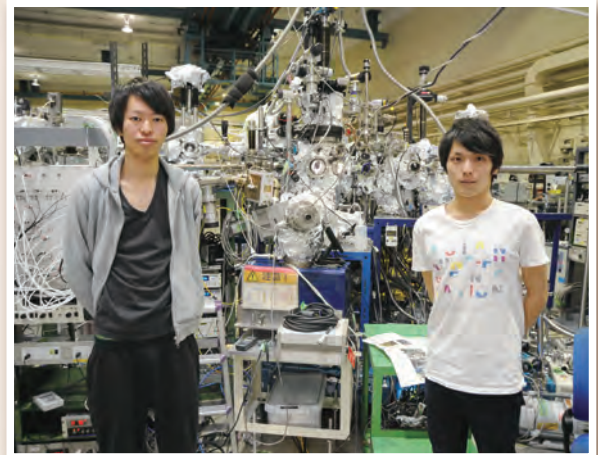
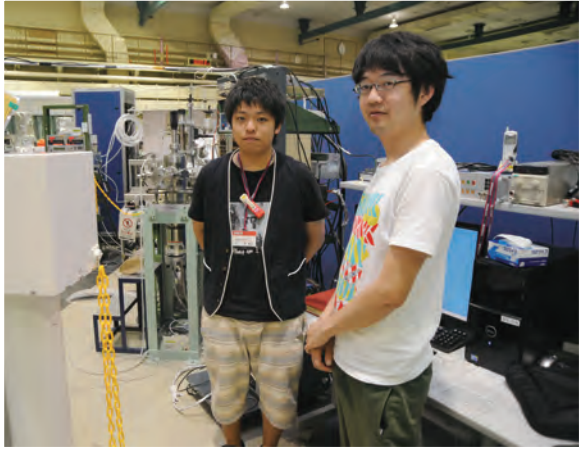

Fig. 2. Photo of BL7B.

▼ Technical Data

Monochromator	3 m Normal-Incidence Monochromator
Wavelength Range	50-1000 nm (1.2-25 eV)
Resolution	$E / \Delta E = 4000-8000$ for 0.01 mm slits
Experiments	Absorption, reflection, and fluorescence spectroscopy, mainly for solids

UVSOR User 1



UVSOR User 2

